

CENTROLLER

TELEPHONE AUTO DIALLER AD11T INSTALLATION AND OPERATING INSTRUCTIONS

PLEASE READ THESE INSTRUCTIONS THROUGHLY BEFORE YOU START INSTALLATION. YOUR AUTODIALLER IS FOR USE IN EMERGENCIES. IT IS IMPORTANT THAT THE AUTODIALLER IS PROPERLY INSTALLED AND YOU UNDERSTAND HOW IT WORKS.

THESE SHOULD BE KEPT IN A SAFE PLACE FOR FUTURE REFERENCE

Approved for correction to telecommunications system specified in the Instructions for use subject to the conditions set out in them.
Approval number S/5116/3/V/504002

How the system operates

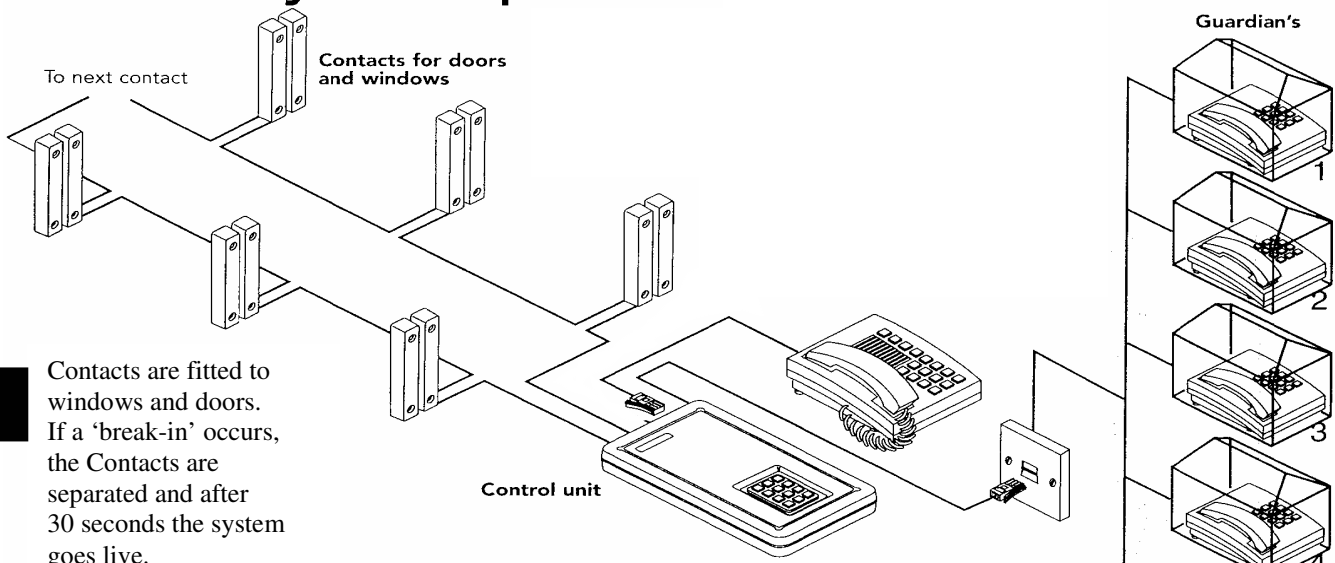

1 Contacts are fitted to windows and doors. If a 'break-in' occurs, the Contacts are separated and after 30 seconds the system goes live.

2 At the same time, the Telephone Auto Dialler begins to dial out on your normal BT Line to 6 pre-programmed that will alert your designated 'Guardian's (neighbour, family or friends) of a potential emergency. It won't stop dialling until it answered by one of them. Telephone Auto Dialler transmits a spoken emergency message giving the Guardian your Home Telephone Number. The message is repeated three times. Having sent the emergency message, the Telephone Auto Dialler will disconnect the call and wait 3 minutes for the guardian to reply. If a telephone call is received in time, the Telephone Auto Dialler will recognize the guardian's call and stop further dialling. When a reply has been received, the telephone Auto Dialler has completed its function. The Guardians can take the action agreed.

1

PLANNING

1A

Start planning your system at your telephone master socket (or extension)

Consider whether you intend standing your telephone on top Of the Security Auto Dialler, or fixing the Security Auto Dialler to a nearby wall.

If your premises have not been converted to the modern telephone plug socket arrangement you should inform British Telecom who will convert your telephone for a nominal charge.

Notify BT by completing the request slip on the loose page supplied with instructions.

1B

Decide which doors and windows are at risk and require alarm contacts

Those on the ground floor, which are not in view of the street are top priority.

Alarm all ground floor doors and windows if possible. First floor windows which are accessible from the roofs of out house or garden wall are at risk.

For maximum security fit Contacts to all external doors and windows. Extra Security can be achieved if Contacts are fitted to a selection of internal doors.

Extra contacts can be obtained from Centroller.

1C

Plan the route of your indoor wiring

You will probably want to avoid running your indoor wiring across the walls and ceilings.

Plan its route carefully to be out of view whenever possible. Run it around window and door frames and under carpets.

1D

You will need these tools

- Electric drill
- Masonry drill bits
- Timber drill bits
- Hammer
- Electrical screwdriver
- Wood screwdriver
- Cross head (Phillips screwdriver)
- Ladder (capable of reaching your roof eaves)
- Wire strippers
- Pencil
- Spirit level (optional)
- Steel tape measure
- Craft knife (Stanley knife)

2

INSTALLING

2A

Installing Batteries.

Stand the Security Auto Dialler Unit on a suitable flat surface or fix to a wall adjacent to the chose telephone socket. Use the two keyholes in the rear of the dialler unit for wall fixing. You will need access to the rear of the unit during the installation process, so attach it loosely first.

2B

Insert the 5 x AA (non-rechargeable) batteries as indicated on the back panel of the Security Auto Dialler Unit. Don't use two alarm batteries. A small electrical screwdriver is required to open the components.



WARNING: Ensure the connector into the BT network is unplugged before inserting or removing the batteries.

If a long "bleep" lasting 8 seconds is heard after inserting the batteries please use new batteries. If the batteries are getting low, the Security Auto Dialler will emit a short "Bleep" approximately every 10 minutes.

Please use new batteries.

2C

Installing the Contacts.

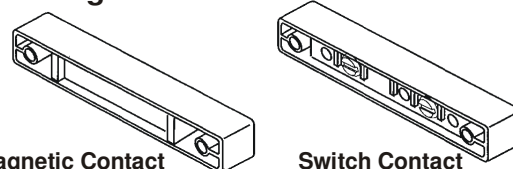

Magnetic Contact

Switch Contact

The contacts can be fitted to windows and doors in several different ways, eg side to side or side to top etc. Ensure that they are no further apart than 5mm when the window/door is closed.

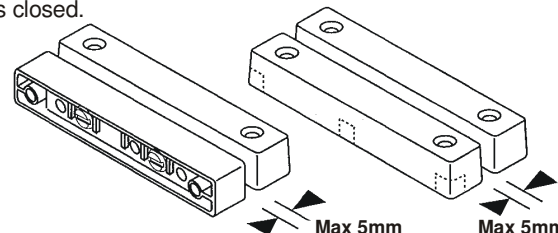

There are 'weak spots' in the Switch Contact (shown by dotted lines) which can be removed for wiring access.

2D

With your first length of twin core wire, bare one core only and feed it into the terminal on the Security Auto Dialler unit marked SENSOR 1.

2E

Feed the Bell wire around walls, window, door frames and under carpets to the nearest window or door you want to alarm. Leave some 'slack' in the wire for when fixing clips are fitted later.

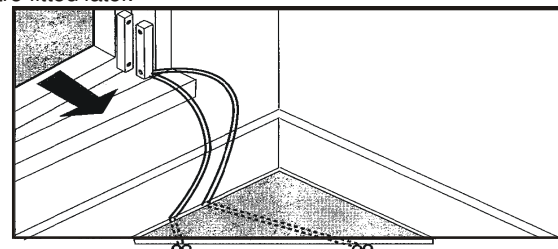

The Switch Contact should always be fitted to the fixed frame not the moving window/door. The Contact should be mounted to allow max. Movement apart from when the window/door is open.

2F

Cut the other end of your first length of twin core wire near to where you have decided to fit the first Switch Contact. Bare the other end of the same core connected to SENSOR 1. Connect to one of the screw terminals of the Switch Contact. Leave the unused core. Tuck it into the wiring access hole before fixing the Switch Contact to the window/door frame.

REAR OF SWITCH CONTACT

First length of wire from SENSOR 1 (see note 2F)

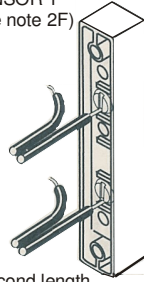

Second length of wire to next switch contact (see note 2G)

2G

With your second length of twin core wire, bare the inner and connect it to the other terminal on the switch contact. Screw fix the switch contact to the fixed frame and the Magnetic Contact to the moving frame.

Continue as 2F (above), by moving on to the next window/door you wish to alarm. Move to the next nearest window or door and finish with a window/door near to the Security Auto Dialler Unit. Up to a maximum 27 Magnetic Contacts can be fitted in this way.

2H

The single core wire from the last Switch Contact returns to the Security Auto Dialler Unit. Connect this wire to the terminal marked SENSOR 2. This last "closes" the "loop". If you wish to add more contacts at a later date remove this last wire to open the "loop" and add more contacts to windows/doors. Do not create a separate "loop".

2I

Before fixing your wiring to walls and door frames you should progress to the completion of 4A. If you are unable to Arm(turn on) the Security Auto Dialler and you hear "check system " it is likely that some of the connections to switch contacts is greater than 5mm. These should be checked. Once you have carried out a "test arm" successfully, finish the installation of the twin core wires by running both single strands under the fixing clips, and securing them across exposed areas of wall as in diagram below.

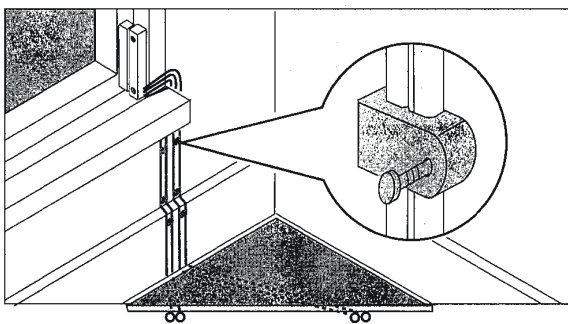

Security Auto Dialler Unit requires certain information to be entered before it will work. Security Auto Dialler Unit requires your Personal Identification number (Pin), your home telephone Number (HTN) (or phone number where the Security Auto Dialler is installed) and at least one Guardian's Telephone Number.

3A

To Store your personal identification number (PIN)

Your PIN up to five digits
Choose any number you can remember easily.
Shown below are the steps for storing your PIN.
Let's say you have chosen 42

PRESS

STO

This starts the STORING sequence

0
PIN

This tells the Security Auto Dialler you are about to store your PIN.

4

Your pin number

2

Your pin number

STO

This ensures that the STORING sequence is complete

3B

To check your PIN

PRESS

RCL

This starts the RECALL sequence

0
PIN

This tells the Security Auto Dialler what you want to recall

Your PIN number will be spoken "Four-Two"

If your PIN number has not been stored correctly the Security Auto Dialler will say "Error"

If this happens you should run through the store sequence again.

3C

To store your home Telephone Number (HTN)

HTN forms part of the emergency message and enables your Guardian's (neighbours, family, colleagues or authorised

Key holders) to identify the location of the alarm (as they may know more that one user of the Security Auto Dialler)

Your HTN must have between four and twelve digits

Let's say your HTN is 123 4567

PRESS

STO

This starts the STORING sequence

9
HTN

This tells the Security Auto Dialler you are about to store your HTN

1

Your Home Telephone Number

2

Your Home Telephone Number etc, etc until the last digit

STO

This ensures that the STORING sequence is complete

3D To check your HTN

PRESS

RCL

This starts the recall sequence

8
HTN

This tells the Security Auto Dialler what you want to recall

Your HTN number will be spoken "Zero-One-Two-etc". If your HTN has not been stored correctly the Security Auto Dialler will say "Error".

If this happens you should run through the store sequence again

3E To store your Guardian's telephone numbers

These are telephone numbers of your Guardian's.

Storing then enables the Security Auto Dialler to phone them in an emergency. A maximum of six telephone numbers can be programmed in the Security Auto Dialler.

Enter the numbers in the same order you will usually wish them to be dialled in an emergency.

IMPORTANT: You must tell the Security Auto Dialler which order you wish the numbers to be called by pressing the appropriate memory number (1-6) before entering the phone number. However this sequence can be changed easily if you wish, see section

Your Guardian telephone numbers must have between four and twelve digits.

Lets say your first Guardian's telephone number is **0987 6543**

PRESS

STO

This starts the STORING sequence

1

This is the memory number, it tells the Security Auto Dialler Control Unit you want to call this number first

0
PIN

Your Guardian's telephone number

9
HTN

Your Guardian's telephone number etc, etc until the last digit

STO

This ensures that the Storing sequence is complete

To enter other Guardian's telephone number repeat as above, but remember to enter the memory number 1,2,3,4,5 or 6 before the first digit of the Guardian's telephone number. You do not need to enter more than one Guardian's telephone number.

3F To check your Guardian's telephone numbers

PRESS

RCL

This starts the recall sequence

?

Enter the Guardian's prefix number (between 1 - 6) you wish to recall.

The appropriate Guardian's telephone number will be spoken, "Zero-One-Two- etc"

If you have not stored the number correctly the Security Auto Dialler will say "Error". If this happens you should run through the store sequence again.

3G To change a Guardian's telephone number

Run through the store sequence as above. After pressing the appropriate 1-6 memory number as you enter your new Guardian's telephone number it will automatically remove the old number. To delete a number completely run through the store sequence as above replacing the Guardian's telephone number with twelve zeros.

It is advisable to write down your Guardian's Telephone Numbers for reference, even though you can ask Security Auto Dialler to recall them.

YOU HAVE NOW FINISHED ENTERING THE INFORMATION REQUIRED FOR THE SETTING

4

ARMING (OR TURNING ON)

Using the Security Auto Dialler

After storing your Personal Identification Number(PIN) , your Home Telephone Number(HTN) and least one Guardian's telephone number your Security Auto Dialler is ready to use.

4A

Arming (turning on) Security Auto Dialler

Before arming the Security Auto Dialler make sure all the doors and windows are closed.

You arm the Security Auto Dialler by using your PIN number

PRESS



This starts the **ARMING** sequence



Your PIN number

After pressing the last digit the Security Auto Dialler should respond immediately. "Bleep, Bleep, Bleep, Bleep"

You now have 30 seconds to leave the premises

(You can **DISARM** the Security Auto Dialler during this period, PRESS **DIS** followed by your PIN, see section)

As you exit the premises your are likely to o through a door with Contacts fitted.

If you do (or any other Contacts are temporarily broken) the Security Auto Dialler will sound an intermittent series of bleeps (four Seconds). If you do not close the door at the end of the 30 seconds, Security Auto Dialler will say "Check System...long bleep" and will stop the arming process.

If you close the door within the original 30 seconds Security Auto Dialler will sound four louder bleeps. This indicates it has successfully armed.

4B

ERRORS

If after pressing ARM and PIN you hear "ERROR"

And not "Bleep, Bleep, Bleep", Security Auto Dialler will not arm.

Check the following: -

You have stored your PIN correctly
(press RCL PIN to check).

You have stored your Home Telephone Number
(press RCL HTN to check).

The Guardian's Telephone No(s)have been stored correctly(press RCL,1,2,3 etc to check).

If you have changed the sequence in which your Guardian's Telephone numbers are stored check that you have Guardian's telephone numbers in all the memories (1-6) listed in your memory sequence.

If after pressing ARM and PIN you hear "Check System -Check System"

Security Auto Dialler will not arm.

Check the following: -

Doors and windows with contacts are securely closed.
The two AA batteries in the Alarm compartment of the Security Auto Dialler unit have not been installed back to front and have not run down.

5

DISARMING (OR TURNING OFF)

5A

Disarming the Security Auto Dialler

You disarm the Security Auto Dialler by using your PIN

PRESS



This starts the DISARMING Sequence



Your PIN number

After pressing the last digit of your PIN the Security Auto Dialler will immediately respond in one of two ways.

"Bleep, Bleep, Bleep, Bleep"

No emergency occurred during the armed period.

OR

"Emergency, Emergency, Bleep, Bleep, Bleep, Bleep"

Security Auto Dialler has disarmed, but has made emergency calls during the armed period. Check with your Guardian's to find out who received the call and what action was taken.

5B

Trouble shooting when disarming the Security Auto Dialler

The Security Auto Dialler Says "Error" while you are entering the Pin.

You may have entered your PIN incorrectly, repeat the disarm sequence by entering DIS followed by the correct PIN.

The Security Auto Dialler Says "Error" when you have only pressed DIS

The Security Auto Dialler was not armed correctly at the last attempt or has already been disarm(possible by another pin holder)

5C

Entry Delay - 30 Seconds

When entering the alarmed premises you will hear a long "Bleep". You have 30 seconds to disarm (switch off) the Security Auto Dialler after opening the first Contacts (probably on your front door).

If you do not disarm the Security Auto Dialler your External siren/strobe (optional)will sound at the end of a 30 second delay period. If you immediately disarm (DIS followed by your PIN) the Security auto Dialler will not call your Guardian's.

If you do not realise it is your own alarm, or you cannot hear your own alarm, after a short period of time your telephone will ring for 5 seconds before being answered by the Security Auto Dialler.

This will be the Guardian acknowledging receipt of the emergency call from the Security Auto Dialler.

IT IS IMPORTANT THAT YOU PICK UP THIS CALL AND INFORMS THE GUARDIAN THAT IT WAS A FORCE ALARM.

The Security Auto Dialler will pick up the call to acknowledge its message has been received, so you will hear it taking over your conversation.

5D

Entry Delay – 0 Seconds

When the alarm is already installed with its own entry delay time, you have the option on Auto Dialler to change the factory set programme form 30 to 0 seconds entry delay time.

5

DISARMING (OR TURNING OFF)

The entry delay time on Auto Dialler can be programmed to zero seconds at any time prior arming the unit. However, we recommend you programme 0 seconds before programming your PIN,HTN,ETN and SEQ codes.

NOTE: The Auto Dialler alarm and dialling batteries must inserted before programming.

Press key	STO	“Bleep”
Press key	8	“Bleep”
Press key	4	“Bleep”
Press key	0 PIN	“Bleep”
Press key	STO	“Bleeceeeep”

The long bleep acknowledges entry delay is now set to 0 seconds To revert back to the factory set 40 seconds delay, firstly unplug the connections to the BT network, remove 3x AA dialler batteries for a few seconds, and then reconnect. Reprogram your PIN, HTN, ETN and SEQ codes in accordance with programming instructions.

6

EMERGENCY PROCEDURE

Once armed if the Security Auto Dialler detects an alarm condition(a door or window open)the external strobe/siren (optional)will go off and it will start dialling your Guardians.

The Security Auto Dialler will call the first in the sequence entered by you.

It will wait 30 seconds to be answered before assuming the first Guardian is out and moving on to the next one.

The emergency message says: -

“THIS IS SECURITY AUTO DIALLER ON..
 (your home telephone number)
..CALLING..
 (Guardian’s Telephone Number)
THERE IS AN EMERGENCY PLEASE
ACKNOWLEDGE”

This message is repeated three times to allow the guardian to note the origin of the message. Your Home Telephone Number will tell them where it is coming from.

IT IS VERY IMPORTANT THAT YOUR GUARDIANS ARE AWARE SECURITY AUTO DIALLER MAY CALL THEM IN AN EMERGENCY, TEST DIAL EACH OFF THEM WHEN YOU FIRST SET UP YOUR SECURITY AUTO DIALLER AND SEND THEM THEIR INDIVIDUAL INSTRUCTIONS.

(On the loose page supplied with the instructions)

7

TEST DIAL

We recommend you carry out a test dial to each of your Guardians to familiarise them with the emergency procedure.

Don’t forget to telephone your Guardian(s) before testing, to check they are at home and confirm you are carrying out a test. You should briefly explain to them how the system works and ask them to call back the Security Auto Dialler immediately to disarm it, as they would in an emergency. You should tell the Guardian what action you would want them to take in a real emergency.

Ask your Guardian to let the phone complete two cycles of ringing, “Brring Brring...Brring Brring”. In the unlikely event that Security Auto Dialler doesn’t connect first time, don’t worry, it will assume no connection was made and dial the number again.

When testing, we recommend you test one Guardian at a time. The simplest way to do this is to change the sequence after each call (see section 8A) making a different Guardian first in the calling sequence.

Arm Security Auto Dialler and then open the alarmed door or window, after 40 seconds the Security Auto Dialler will activate and start dialling your first Guardian.

The Guardian must phone your Home Telephone Number immediately the Security Auto Dialler has finished the third repetitions of the emergency message. Security Auto Dialler will wait three minutes for the return call.

When the Guardian returns its call it will say three times

“SECURITY AUTO DIALLER ACKNOWLEDGES ON
(Your Home Telephone Number)”

After the Security Auto Dialler has received a return call from the Guardian it has then completed its function and will cease further dialling.

8A Changing the sequence of your stored Guardian's telephone numbers

Lets say you have three Guardian's numbers. The Auto Dialler will ring the one you have installed with memory number 1 first, 2 second, and 3 third.

Supposing your Guardian 1 is on holiday. You therefore want Guardian 2 to be called first (to save time in an emergency).

PRESS

STO This starts the STORING sequence.

7 SEQ This tells the Auto Dialler you wish to change the SEQUENCE

2 This tells the Auto Dialler you want it to call Guardian memory number 2, first in the automatic sequence.

3 This tells the Auto Dialler you want it to call Guardian memory number 3, second in the automatic sequence.

1 This tells the Auto Dialler you want it to call Guardian memory number , third in the automatic sequence.

STO This ensures that the STORING sequence is complete.

To check your new sequence

RCL This starts the recall sequence

7 SEQ This tells the Auto Dialler you wish to check the SEQUENCE

The new sequence will be spoken "Two - Three - One etc" If you have not stored the new sequence correctly the Auto Dialler will respond with the factory set sequence "One - Two - Three - Four etc." or the last sequence you entered correctly.

To delete a number completely run through the Store sequence in section **3G** above, replacing the Guardian's Telephone Number with twelve zeros.

You can change the sequence as often as you like, you may have one sequence while you are out in the daytime and another for the evening.

8B Automatic Rearm

The Auto Dialler will automatically rearm after receiving an 'acknowledge message' from a Guardian (see section 6).

We recommended this feature is stored before entering your PIN, HTN, and Guardian telephone numbers. If you have already entered these, they should be deleted by removing the 3 x AA batteries from the dialler slot in the back of the Auto Dialler. Don't forget to then re-enter your PIN, HTN, and Guardian telephone numbers.

Supposing your first Guardian visits your premises and discovers a false alarm. They will not need to enter the premises to rearm the Auto Dialler if this features is already selected and they have acknowledged the emergency call.

This feature is selected before arming.

PRESS

STO This starts the STORING sequence

8 Automatic rearm code

1 Automatic rearm code

0 Automatic rearm code

STO A 3 second "sleep" completes the STORING sequence

8C Setting the entry delay to zero seconds

We recommend this features is store before entering your PIN, HTN, and Guardian telephone numbers. If you have already entered these, they should be deleted by removing the 3 x AA batteries from the dialler slot in the back of the Auto Dialler. Don't forget to then re-enter your PIN, HTN, and Guardian telephone numbers.

PRESS

STO This starts the STORING sequence

8 Zero delay code

3 Zero delay code

0 Zero delay code

STO A 3 second "sleep" completes the STORING sequence

The Security Auto Dialler has Two trigger inputs marked NC Closed voltage free Contacts (terminal 1 & 2) and Negative Trigger (terminal 3 & 4).

1. NC Closed Voltage Free Contacts normally used in conjunction with pair of magnetic contacts, wired in series. When the connection is broken (i.e. open circuit), the Auto Dialler will go into alarm mode.
2. Negative Trigger (terminal 3 & 4) can be used to connect standard alarm systems.

You can use only one input trigger at one time, can't use both triggers at same time.

1. To connect a Industrial Panel to Auto Dialler

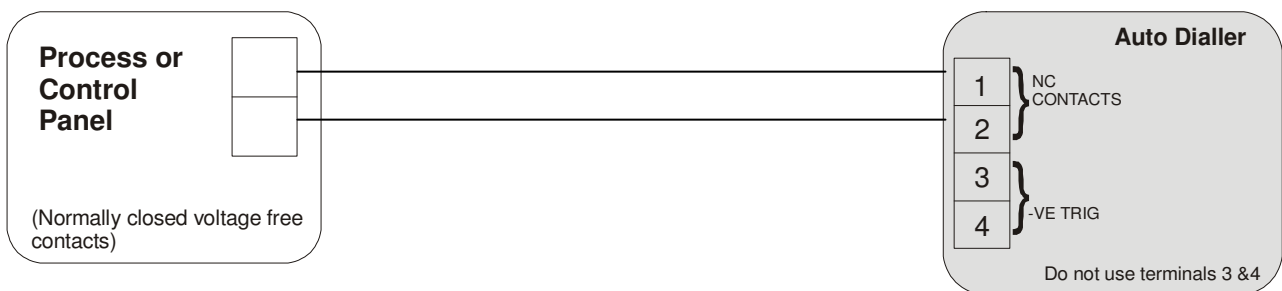

2. To connect Auto Dialler to a -ve trigger domestic or commercial alarm output

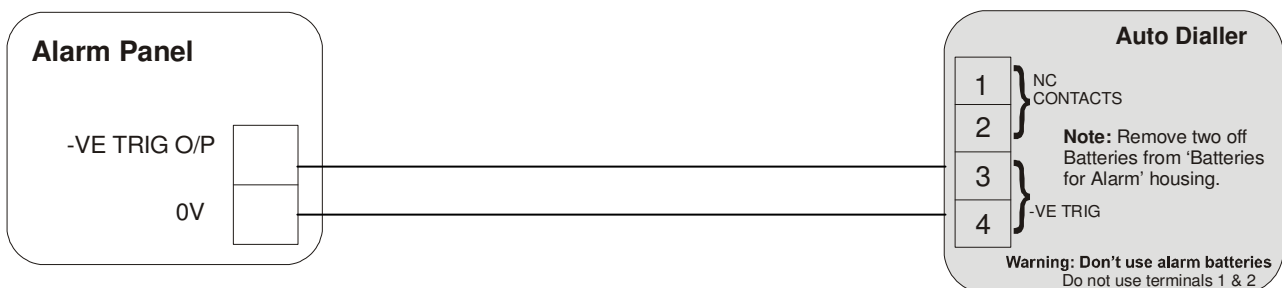

3. To connect a PIR sensor to Auto Dialler

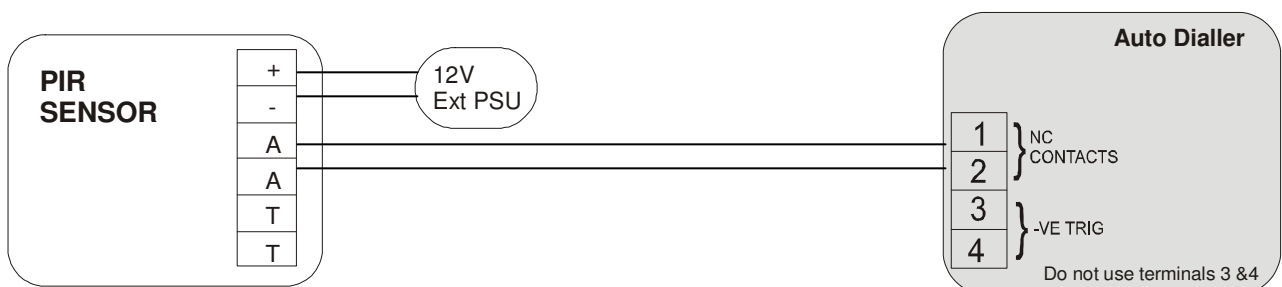

10 CONDITIONS OF USE

Your security Auto Dialler unit:

Can be connected to a normal 'exchange line' socket (An 'exchange line' or Plug or Socket terminating Network (PTSN) as it is sometimes called is a line coming into your premises with its own separate telephone number)

Can be connected to telephone extension sockets off your 'exchange line'

Will work with either ordinary or special feature telephones plugged into its telephone port.

Should be in its disarmed condition (switched off) if you wish to use the main telephone socket (exchange line) or extension socket it is connected to, to make a telephone call or use any other telephone equipment, example: - a fax or a modem

Your Security Auto Dialler Unit:

Cannot be programmed to make 999 calls to the Emergency Services.

Should not be connected to a pay phone.

Should not be connected to an answering machine unless it can answer calls in less than 8 seconds.

Should not be connected to a telephone extension socket when another Security Auto Dialler is already connected to an extension socket on the same exchange line.

Should not be connected to a socket marked 'WARNING' connects only apparatus complying with BS6301 to this port unless advice from a qualified telephone engineer is obtained first.

Your Security Auto Dialler unit is approved for:

- Auto calling (emergency only)
- Series connection (for main apparatus)
- Automatic answering

Any other usage will invalidate the approval of Security Auto Dialler, if as a result it then ceases to comply with the standards against which approval has been granted.

1 YEAR GUARANTEE

Your Centroller Security Auto Dialler is guaranteed against defects due to faulty materials or workmanship for a period ONE YEAR from installation.

A Security Auto Dialler developing a defect within that period will be repaired or replaced with an equivalent unit without charge

Damage caused to the Security Auto Dialler Through accident misuse or neglect is excluded from its guarantee.

Our decision on all matters relating to functional and defective parts shall be conclusive. All defective parts replaced shall become our property.

This Guarantee is valid in the UK only.

THIS GUARANTEE DOES NOT EXCLUDE OR RESTRICT YOUR COMMON LAW OR STATUTORY RIGHTS.

Security Auto Dialler serial no:.....
(On the reverse side of Security Auto Dialler)

Date of purchase

TECHNICAL SPECIFICATION

Security Auto Dialler Unit

Supply voltage	4.5v(3 x AA batteries)
Dialling	Up to 6 telephone numbers Of between 4 & 14 digits tone dialling only.
Attempts	10 Attempts for each number over an 8 to 9 hour period. (including dialling time)
1	5s
2	10m
3	10m
4	10m
5	30m
6	1hr
7	2hr
8	2hr
9	2hr
10	2hr
REN	1
Detection	— Dial tone, busy tone & ring tone
Telephone port	Provided on Security Auto Dialler to accept BT type plug to BS6312. Voltage drop between main apparatus and PTSN will not exceed 0.1v (at 40mA)
PTSN interface	Via flexible cord and plug (to BS 6312) provided
Approval	Approved to BABT requirements for connections to PTSN (direct exchange line)
Speech Synthesis	Factory set voice message communicated through PTSN gives details of emergency location
Alarm supply voltage	3.0v (2 x AA batteries)
Alarm inputs (Terminals 1&2)	1 channel normally closed inputs minimum loop current 100 micro Amps
(Terminals 3&4) -VE Trigger	Normal 3Vdc(min) to 24V dc(max) Alarm 0.8V dc to -0.7V dc
Temperature range	0 to 40 degrees centigrade
Dimensions in mm	47h x 460w x 240d
Net weight in grams	670gm



HELP LINE

In the event of problem, please contact our
Technical Department

Email: sales@centroller.co.uk

01784-454748

Centroller Ltd
Surrey House
189 London Road
Staines Middx
TW18 4HR

Design & Manufactured in the UK



NOTES